



# *A World Ahead in Analyzer Technology*

*Carbon/Sulfur Analyzers  
EMIA Series*

Excellence in gas analyzers since 1957

Over 180 years of JY optical experience

The expertise of Horiba combustion technology



EMIA SERIES CARBON/SULFUR ANALYZERS

# A World Ahead in Analyzer Technology

The Horiba Advantage combines advanced combustion technology with a unique, patented design. Horiba first introduced infrared gas analyzers for emission and air monitoring in 1957. Today, Jobin Yvon is the only company that offers the experience of Horiba combustion technology and over 180 years of expertise and excellence in optics and spectroscopy. This powerful combination offers the Horiba Advantage to users around the world. The JY ALLIANCE program further strengthens the Horiba Advantage through a global commitment to customer support.

The Elemental Metal Infrared Analyzer (EMIA) Series measures gases extracted during combustion in a programmable High Frequency (HF) furnace directly with no conversion. Compared to instruments using conversion and trapping, direct analysis with 4 Non-Dispersive Infrared (NDIR) detectors results in a simpler instrument with improved accuracy, less loss of gas, less reagent use and faster, easier maintenance with lower operating costs. A variety of models allow you to select the furnace system that is best suited to your target samples and applications. All models offer Windows software with onboard help and automatic self-diagnostics as standard features.

You have a choice in the matter of what elemental analyzer to purchase for your laboratory. But only JY can provide the Horiba Advantage...make it your choice.

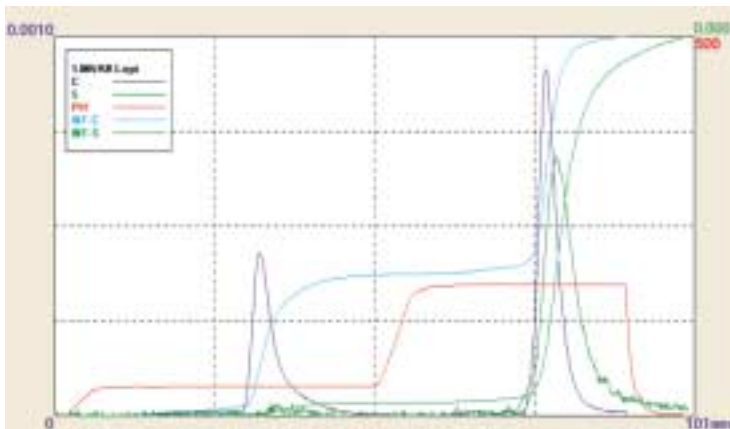

Patented PCC (Plate Current Control) opens up new possibilities such as phase analysis by being able to program the temperature in up to 10 steps.

For very low concentrations, the basic combustion method without special sample preparation does not produce good results due to surface contamination. By combining the advantages of the EMIA Series induction furnace and the unique programmable temperature curve capability, it is possible to separate the concentrations from the surface and the sample itself without long and tedious sample preparation and with the simplicity and speed of a conventional HF analyzer.



# The Horiba Advantage... A matter of choice.



Backed by the ALLIANCE Service Program with an online spare parts catalog and user forum. Visit [www.jyhoriba.com/emission/alliance](http://www.jyhoriba.com/emission/alliance)



- 1** Double Auto Cleaner option features two brushes to simultaneously clean the combustion tube and the cylindrical dust filter after each measurement. The dust is removed to the dust box by a difference in pressure, which avoids the need for an external vacuum cleaner.
  - Minimizes manual maintenance
  - Improves accuracy by reducing the absorption of combustion gases by dust
- 2** Cylindrical stainless steel dust filter is heated to provide stable analyses with extremely low gas absorption, especially for SO<sub>2</sub>.
- 3** Patented Programmable Temperature Control provides optimized combustion and extends the flexibility to a wide range of samples and applications.
- 4** Real-time simultaneous detection of CO/CO<sub>2</sub>/SO<sub>2</sub> without the need for oxidizing or trapping reagents.
  - Improves accuracy — no converter efficiency effect
  - Simpler and shorter gas circuit
  - Less reagent required
  - Quick and low-cost maintenance
  - Less possibility for leakage in the gas circuit

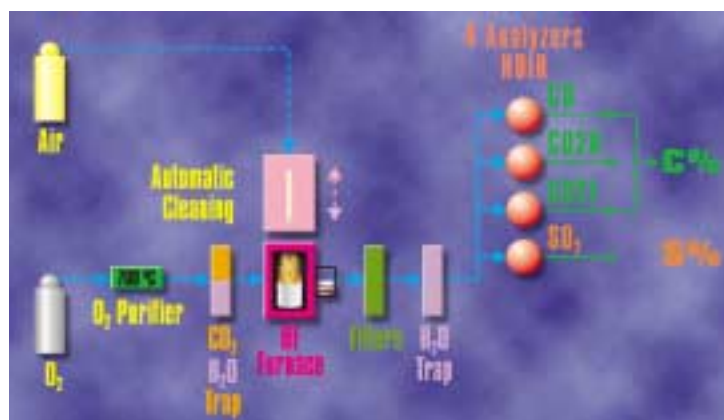

The Horiba Advantage offers 4 NDIR detectors to ensure accurate measurement of all gases with no conversion or trapping and automatic cleaning after each analysis.

# Simple and powerful software for every day use

EMIA for Windows software provides all the tools necessary to ensure fast and easy analysis. The well-organized and customizable features allow user configuration for a custom environment. The features are accessed from a central analysis screen to make analysis and reporting simple and efficient.



Measurement screen updates real time numerical and graphical display of analysis.

- ① Real time numerical analysis results display
- ② Real time extraction graph of each element displayed with plate current curve for furnace
- ③ Display of analysis results, mode, sample name and sample weight with automatic update of the next stored value upon completion of an analysis
- ④ Sample memory stores and displays the next analyses
- ⑤ Comprehensive help text with onboard illustrated manual and self-diagnostics including warning and caution alarms
- ⑥ Auto calibration functions can be optimized to meet specific requirements for single and multi-point calibration
- ⑦ Balance interface for automatic transfer and storage of weights
- ⑧ EMIA network ready software provides a variety of export formats and standard or custom reporting

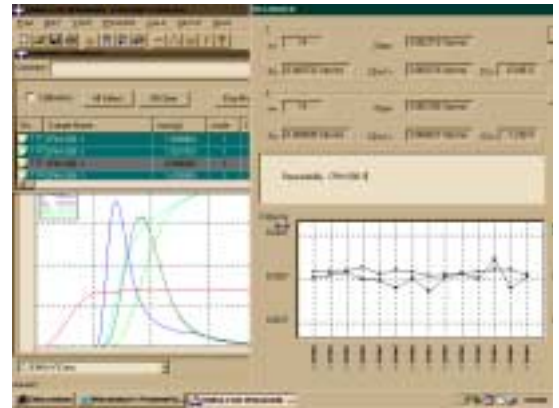

Comprehensive data processing functions and graphics with SPC (Statistical Process Control) including partitioning, overlaying and subtraction, as well as section analysis.

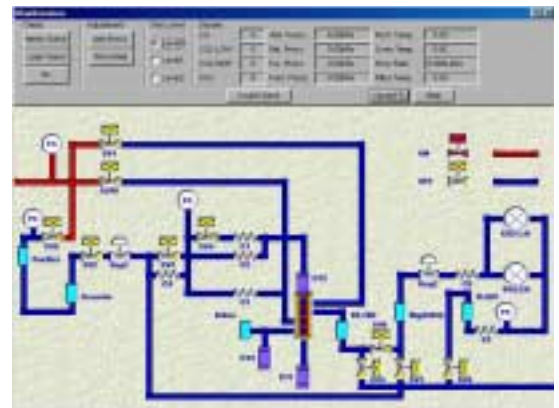

Comprehensive Maintenance Program displays total system status and allows easy checking for leaks, mechanical problems, flow rates, temperatures and signal levels.



Counter screen displays total usage of any replacement item from O-rings to the oscillator tube and alarms at user-defined levels for each.

# The Horiba Advantage... A matter of choice.

Create the instrument that's right for you. Choose from over 15 models plus a wide range of options and automation accessories. See back page for details and specifications.



## EMIA 820V Series

High performance analyzers with outstanding accuracy of less than 0.3 ppm (0.00003% m/m)



## EMIA 320V Series

Standard performance analyzer for a wide range of applications



## EMIA 220V Series

Practical analyzer ideal for production or quality control



## EMIA 8100 Series

Electric Resistance Furnace Analyzers



**Modular options for partial or complete automation provide unattended analysis around the clock.**

Autosampler (shown), Accelerator dispenser, Automatic balance unit, Crucible stocker with pre-burning furnace and sample stocker options



Pure Metals • Precious Metals • Steel • Cast Iron • Copper • Alloys • Ores • Cement • Ceramics  
Carbides • Nickel • Minerals • Coal • Coke • Oxides • Oil • Ashes • Catalysts • Lime • Gypsum • Soils  
Rubber • Leaves • Soot • Tobacco • Waste • Sand • Titanium • Glass • And More...

## HARDWARE SPECIFICATIONS

Models		EMIA-V Series			EMIA-8100 Series	
		EMIA-820V	EMIA-320V	EMIA-220V	EMIA-8100H	EMIA-8100A
		Simultaneous Carbon/Sulfur analysis			Simultaneous Carbon/Sulfur analysis	
		EMIA-821V	EMIA-321V	EMIA-221V	EMIA-8110H	EMIA-8120A
		Carbon analysis			Carbon analysis	
		EMIA-822V	EMIA-322V	EMIA-222V	EMIA-8120H	EMIA-8120A
		Sulfur analysis			Sulfur analysis	
<b>Analysis principles</b>		Infrared light absorption during combustion in Oxygen flow (high-frequency furnace method)			Infrared light absorption during combustion in Oxygen flow (tube-shaped electric resistance furnace method)	
<b>Analysis range</b>		Carbon: 0 to 6%; Sulfur: 0 to 1%, Up to 100% is possible by decreasing the sample weight.				
<b>Sample mass</b>		1.0g standard				
<b>Precision* with combustion of a reliable steel standard sample and NOT GAS DOSE ONLY.</b>	<b>Carbon</b>	≤ 0.3 ppm or ≤ 0.5% RSD; whichever is met	≤ 2 ppm or ≤ 1.0% RSD; whichever is met	≤ 5 ppm or ≤ 1.0% RSD; whichever is met	≤ 1.5 ppm or ≤ 0.75% RSD; whichever is met	≤ 2 ppm or ≤ 1.0% RSD; whichever is met
	<b>Sulfur</b>	≤ 0.3 ppm or ≤ 0.5% RSD; whichever is met	≤ 2 ppm or ≤ 1.5% RSD; whichever is met	≤ 5 ppm or ≤ 1.5% RSD; whichever is met	≤ 1.5 ppm or ≤ 2.0% RSD; whichever is met	≤ 1.5 ppm or ≤ 2.0% RSD; whichever is met
<b>Sensitivity (minimum reading)</b>		0.01ppm		0.1ppm	0.01ppm	
<b>Analysis time</b>		Normally 30 to 60 seconds (after start of combustion), varies according to the characteristics of the sample.				
<b>Combustion furnace method/furnace structure</b>		<ul style="list-style-type: none"> <li>High-frequency induction furnace method with patented combustion control function; Anode output: 2300W; frequency: 20MHz; plate current: variable up to 500mA; automatic control possible (10 slopes maximum)</li> <li>Constant dust filter heating function (EMIA 820 Series only)</li> </ul>			<ul style="list-style-type: none"> <li>Tube-shaped electric resistance furnace with temperature and Oxygen pressure increase function to increase combustion power. Operating temperature range: 400 to 1450° C</li> <li>Temperature programming function with up to 10 slopes</li> </ul>	
<b>High-frequency furnace automatic cleaning mechanism</b>		Built-in as standard	Option	Option	—	—
<b>Oxygen gas purifying unit</b>		Built-in as standard	Option	Not available	Built-in as standard	Not available
<b>Electronic balance</b>		Option with RS232C interface to allow automatic transfer of sample weight to computer.				
<b>Physical data</b>		Depth 912mm (36in) Width 580mm (23in) Height 950mm (37in) Weight 170kg (374lbs)			Depth 803mm (32in) Width 690mm (27in) Height 751mm (30in) Weight 90kg (198lbs)	

### \*Conditions for Precision

- With reliable steel standard samples recommended by Horiba
- With Horiba crucibles pre-burned at 1,000° C for at least 30 minutes
- With Oxygen carrier gas of purity greater than 99.5% and THC (Total Hydrocarbon) 1 ppm or less

## EMIA-V Series/EMIA-8100 Series

### SYSTEM SPECIFICATION

#### Data processing:

Standard PC required for operation which can be provided as an option.

#### External output:

##### EMIA-V Series:

- RS-232C

##### EMIA-8100 Series:

- RS-232C Analog output 0 to 2 V DC (C/S/temperature)

**Leak check function:** Automatic with full or partial selection possible

### DATA PROCESSING SPECIFICATIONS

(Available except for EMIA-220V)

- Graphics data memory function
- Statistical processing function

- Graphics data enlargement/compression processing
- Processing of maximum of four partitions on a single screen
- Overlay processing
- Differential operation processing
- Section operation processing

### REQUIRED FACILITIES

#### Supply voltage:

Combustion section: 200/220/240V AC (specify)

Processing section: 100/120/200/220/240V AC (specify)

**Amplitude of power supply fluctuation:** within ± 10% of the reference voltage

**Frequency:** 50/60Hz

### Required power:

Combustion section: 5 kVA max.

Processing section: 0.5 kVA max.

**Ground:** ground resistance of 10 Ω or less

### Power supply line noise:

500Vp-p pulse width 1 μsec or less

### Ambient environmental requirements:

Temperature: 5 to 35°C

Humidity: 45 to 80%

**Gases:** Oxygen purity of 99.5% with THC of < 1 ppm at 0.3 mPa

Dry air or Nitrogen for driving the air cylinder (EMIA-V Series) and for opening/closing the combustion tube door (EMIA-8100), supply pressure 0.35 MPa

### Connections:

Power supply (combustion section): Provide a grounded 200/220/240V outlet within 15m of the main unit.

Oxygen: Provide a connector suitable for a 6/4mm diameter Teflon tube within 5m of the main unit. Dry air or Nitrogen: Provide a connector suitable for a 6mm/4mm diameter Teflon tube within 5m of the main unit.

### OPTIONS

- Gas doser
- Halogen Trap Unit
- Automatic Sampler (20 positions)
- Crucible Stocker
- Automatic Balance
- Automatic Accelerator Dispenser
- Sample Stocker (24 samples)
- RS-232C cable (3m)
- Consumable supplies

**In France:**  
Jobin Yvon S.A.S.  
16-18, rue du Canal  
91165 Longjumeau Cedex  
Tel: (33) 1/64 54 13 00  
Fax: (33) 1/69 09 90 88

**In Japan:**  
Horiba Ltd.  
2 Miyahogashi, Kisshoin  
Minami-ku, Kyoto 601-8510  
TEL: (81) 75 313 8121  
FAX: (81) 75 321 5725  
www.horiba.com

**Germany:** (49) 89/46 23 17-0  
**Italy:** (39) 2/57 60 56 90  
**U.K.:** (44) 20/82 04 81 42

**In the USA:**  
Jobin Yvon Inc.  
3880 Park Avenue  
Edison, NJ 08820  
Tel: 1-732-494-8660  
Fax: 1-732-494-8796  
E-mail: emission@jyhoriba.com

**China:** (86) 10 6849 2216  
**Spain:** (34) 91/724 16 57  
**Other Countries:** Contact Jobin Yvon S.A.S.

