

OEM Compact Monochromator MF-61

The new OEM compact monochromator MF61 have been designed around an aberration-corrected, type IV concave holographic grating.

The diffraction grating plays a triple role:

- Collimator
- Dispersing
- Focusing

With a 100 mm focal length and a F/3.5 aperture, the new MF61 is equipped with a rapid scanning direct drive system; the wavelength drive is directly coupled to a stepper motor.

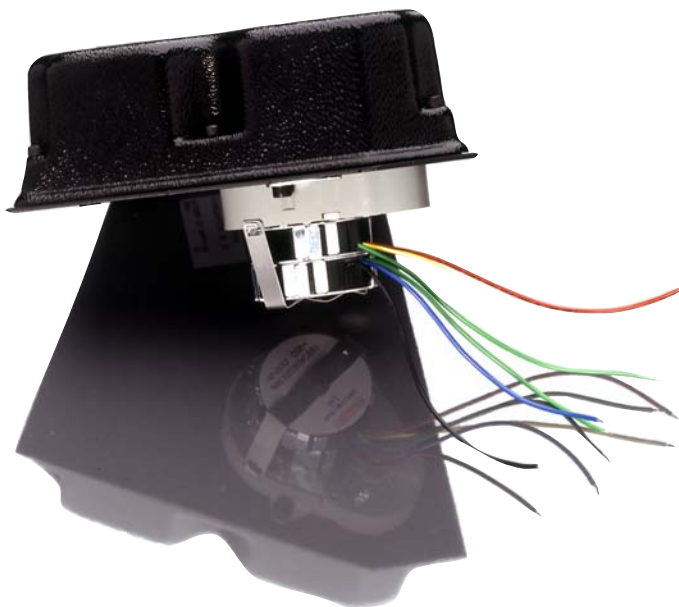

4 models are available,
from the UV range to the IR range.

The MF61 is made specifically for volume orders. We can offer custom modifications to volume customers.

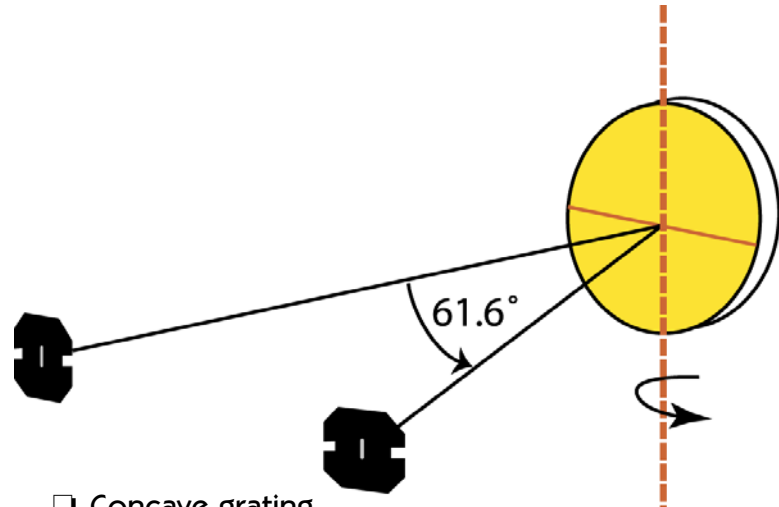

- Concave grating.
- Focal length : 100 mm.
- Deviation : 61.6°.
- Aperture : F/#:3.5.
- Dispersion : 8 nm/mm.

Different models of slits are proposed depending on the resolution requested by the customer. The basic model is supplied with a pair of slits of 0.5 or 1 mm width.

Different models of stepper motors are proposed depending on the resolution requested by the customer.

In the basic model, the MF61 is equipped with a 4 phase stepper motor with 12000 step/360°.

The spectral range can be scanned in less than 1 sec.

Gratings & OEM Division

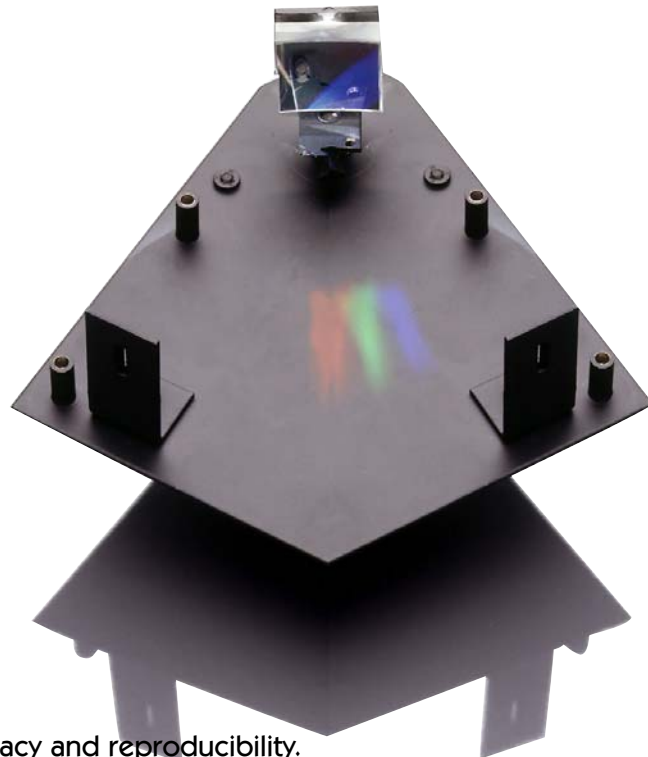
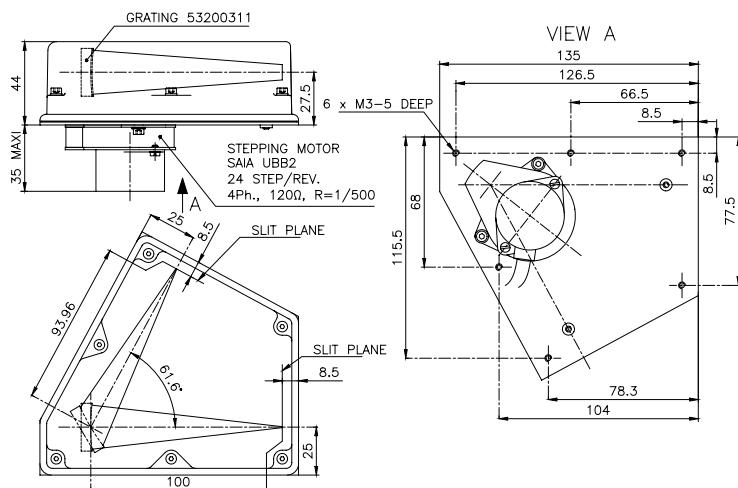

Performances:

- Resolution : 1 nm FWHM (with 100 μ m * 4 mm slits)
- Wavelength accuracy: \pm 1.5 nm with a curve fit
- Step repeatability : \pm 0.2 nm (with 1200 g/mm)

More sophisticated motors can yield better wavelength accuracy and reproducibility.

Options:

- SMA connectors (instead of the pair of slits)
- 2 phases stepper motor
- Other on request

Applications:

The main applications are fluorescence, medical diagnostics, spectrophotometry, environment, clinical chemistry, semiconductor characterization.

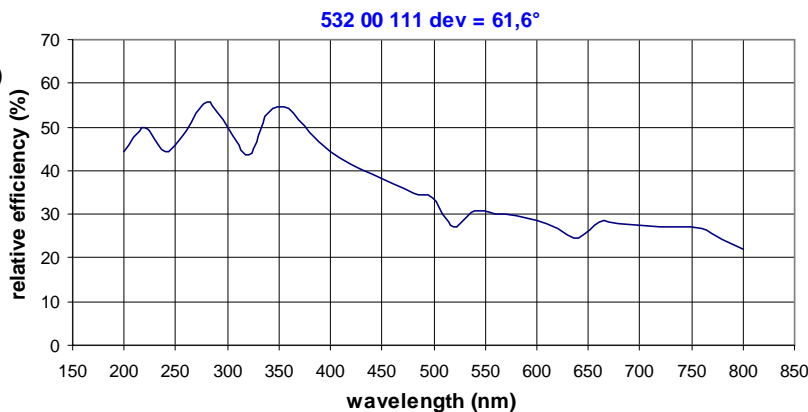

Spectral efficiency curve of the UV model

	UV	VIS	NIR	IR
Spectral Range	190 - 800	350 - 800	400 - 1600	800 - 3200
Ref.	MF 61 UV	MF 61 V	MF 61 NIR	MF 61 IR

We are pleased to work with you to find a suitable solution to your requirements.

In North America:

HORIBA Jobin Yvon Inc.
3880 Park Avenue
Edison, New Jersey
08820, USA
Tel: +1 732 549 7405
Fax: +1 732 548 9725
Email: oemsales@jobinyvon.com

In France:

HORIBA Jobin Yvon S.A.S.
16-18, rue du Canal
91165 Longjumeau cedex
France
Tel: +33 (0)1 64 54 13 63
Fax: +33 (0)1 69 09 93 19
Email: info@jobinyvon.fr

Others areas:

China, Beijing: +86 (0) 10 6849 2216
China, Shanghai: +86 (0) 21 6447 9785
Germany: +49 (0) 89 46 23 17 0
Italy: +39 0 2 57 60 30 50
Japan: +81 (0) 3 3861 8234
U.K.: +44 (0) 20 8204 8142

HORIBAJOBIN YVON

Explore the future

HORIBA